

## Premium Preparation 1600 mm Meat & Fish Processing/ Washing Table

ITEM # \_\_\_\_\_

MODEL # \_\_\_\_\_

NAME # \_\_\_\_\_

SIS # \_\_\_\_\_

AIA # \_\_\_\_\_

**132963 (TLC1600EN)**

 Meat and Fish Processing/  
 Washing Table with  
 perforated and removable  
 Plates, knife holder,  
 polythene cutting board,  
 drain, scraping hole and  
 upstand, 1600mm

### Short Form Specification

**Item No.** \_\_\_\_\_

50mm high worktop in 304 AISI stainless steel, 1,5mm in thickness, sound-deadened, anti-drip edges and welded corners. Integral radiused rear upstand, h=100mm with 10mm radius. All-round apron. Round section legs and feet in 304 AISI stainless steel, 50mm in diameter. N.1 polythene cutting board 1130x225x25h mm, drain and waste scraping hole on front.

### Main Features

- Sturdiness, stability and reliability of table accurately tested.

### Construction

- Table can be equipped with a mobile bin with lid for waste disposal (optional accessory).
- Round section legs with feet in 304 AISI stainless steel, 50 mm in diameter, adjustable in height by +0/-40 mm.
- Unit features a 20 mm deep recessed surface, a polythene cutting board and a scraping hole on the front, perforated and sectionated removable tops, an easily removable GN liquid container and a knife holder. Knife sanitizer can be supplied as optional.

### Optional Accessories

- Single drawer GN 1/1, 400mm PNC 855280
- Single drawer, 600mm PNC 855281
- Lower shelf for 1600mm for units PNC 855284
- Set of 4 wheels (2 with brake) d. 100mm PNC 855288
- 3-sided underframe for 1600mm tables PNC 855292
- Additional drawer, 600mm (to set up a chest of 2, 3, 4 drawers) PNC 855295
- Additional drawer GN 1/1, 400mm (to set up a chest of 2, 3, 4 drawers) PNC 855298
- Mixer tap with swivel spout 3/4", single hole PNC 855319
- Elbow operated mixer tap with spout 3/4", single hole PNC 855322
- Elbow operated mixer tap with short spout 3/4", single hole PNC 855323
- Elbow operated tap with spray arm and spout, single hole PNC 855324
- HD mixer tap with spray arm 3/4", single hole PNC 855326
- Foot operated mixer tap (hot and cold) with spout 3/4" PNC 855328

APPROVAL: \_\_\_\_\_

## Key Information:

<b>External dimensions, Width:</b>	1600 mm
<b>132963 (TLC1600EN)</b>	
<b>External dimensions, Depth:</b>	700 mm
<b>External dimensions, Height:</b>	1000 mm
<b>Upstand Dimensions, Height:</b>	100 mm
<b>Upstand Dimensions, Depth:</b>	13 mm
<b>Upstand Dimensions, Radius:</b>	R=10
<b>Bowls number</b>	1
<b>Bowl dimensions</b>	1670x320xH180
<b>Worktop thickness:</b>	50 mm
<b>Net weight:</b>	60 kg

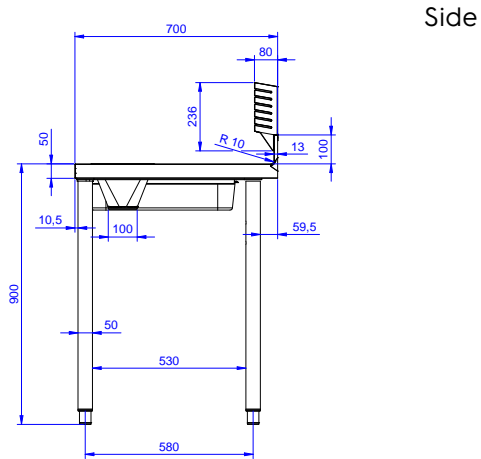
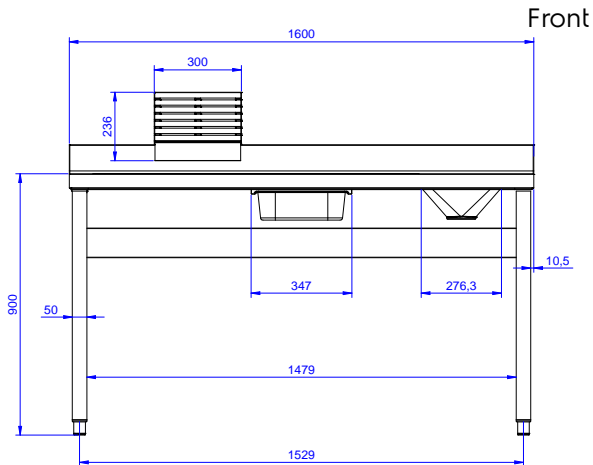

D = Drain

